

### SPECIFICATION

MODEL	MA-10G12(S)		
FREQUENCY	50 Hz	60 Hz	
RATED LOAD	1100 kg	900 kg	
ROPE SPEED	12 m/min	14 m/min	
LENGTH OF WINDING	ø14×160m (7Ls)		
MOTOR	OUTPUT	POLES	VOLTAGE
	2.5kW	4P	200V
ISO CLASS	M5		
WEIGHT	450 kg		

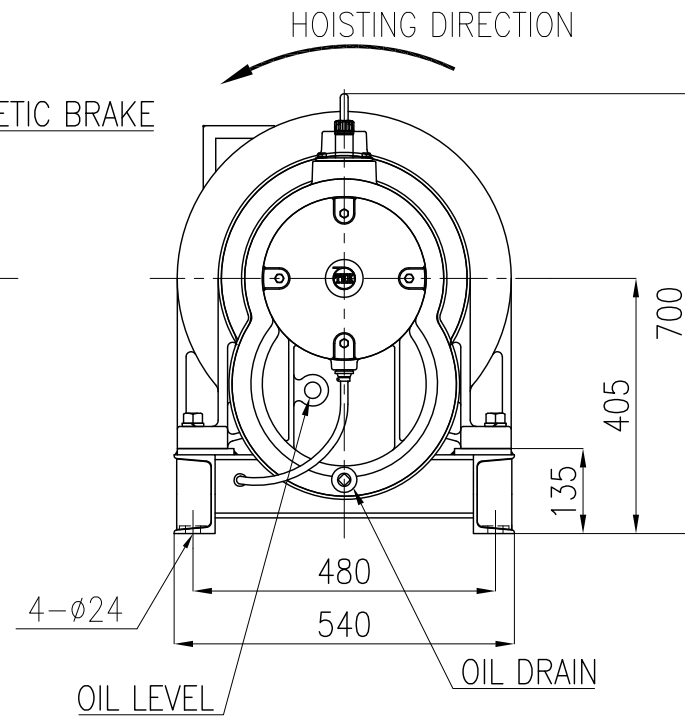
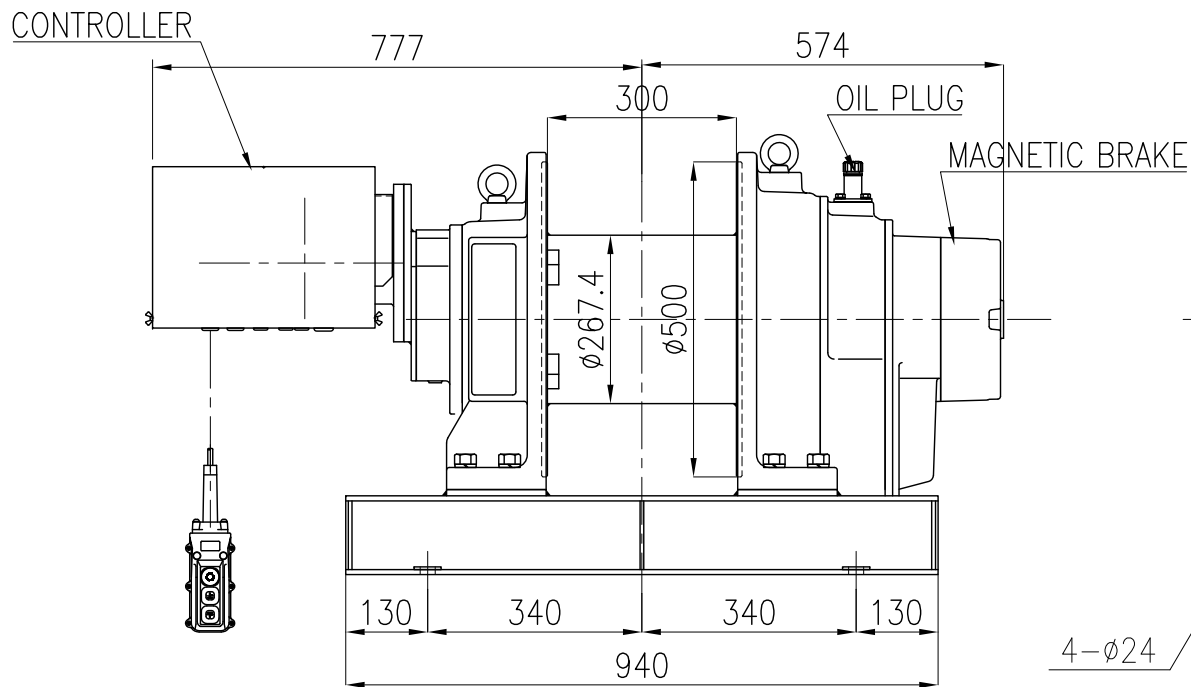

TYPE	MA-10G12(S)
NAME	OUTLINE
DRAWN No.	051464