

### SPECIFICATION

MODEL	MA-25(S)		
FREQUENCY	50 Hz	60 Hz	
RATED LOAD	2000 kg	1700 kg	
ROPE SPEED	47 m/min	56 m/min	
LENGTH OF WINDING	ø16×220m		
MOTOR	OUTPUT	POLES	VOLTAGE
	18.5kW	4P	200V
ISO CLASS	M5		
WEIGHT	660 kg		

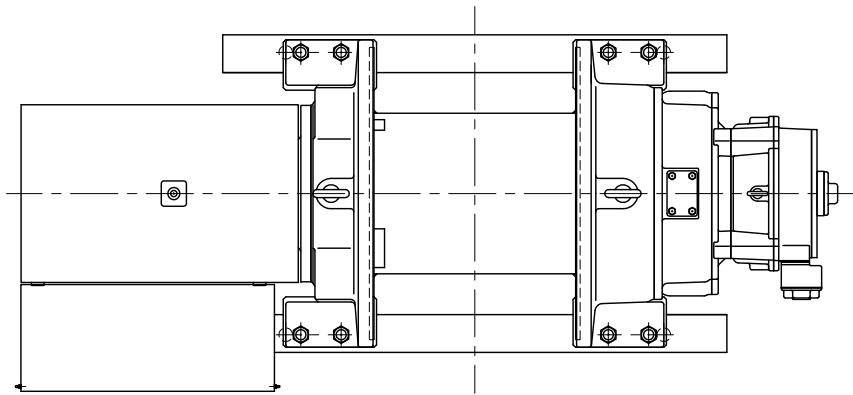

CONTROLLER

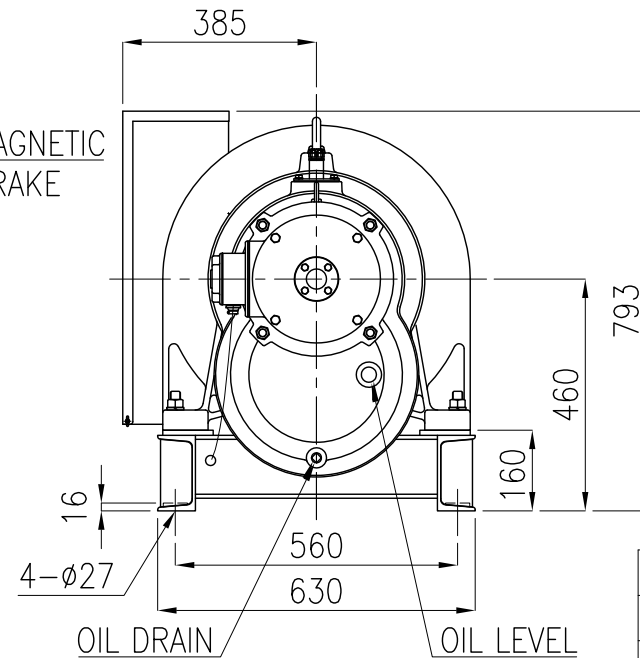
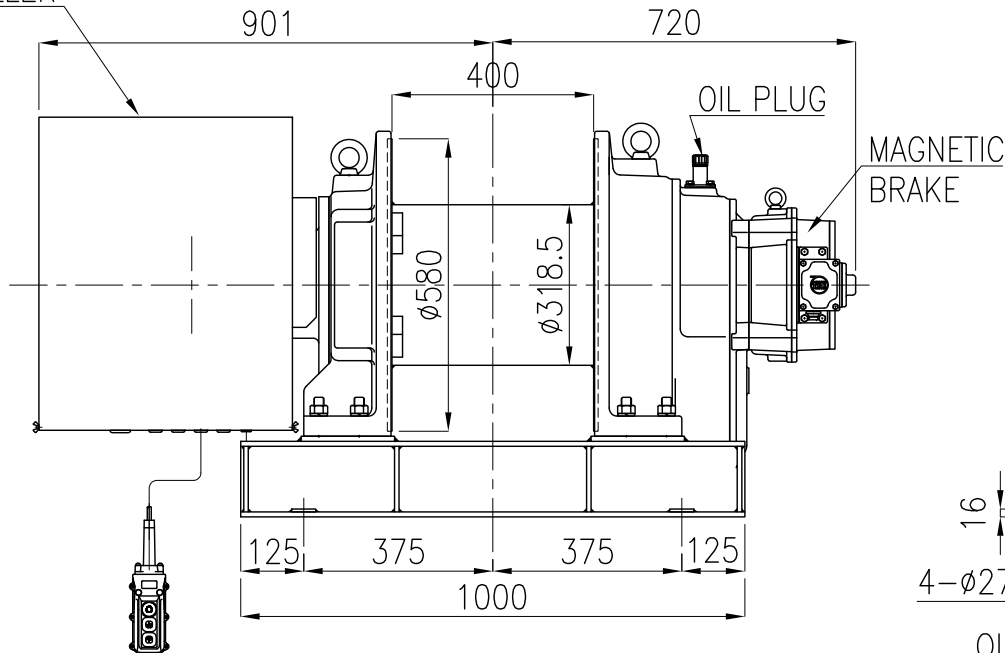

TYPE	MA-25(S)
NAME	OUTLINE
DRAWN No.	051449