

SPECIFICATION

MODEL	MA-25G10(S)		
FREQUENCY	50 Hz	60 Hz	
RATED LOAD	2000 kg	1650 kg	
ROPE SPEED	10 m/min	12 m/min	
LENGTH OF WINDING	ø16×220m		
MOTOR	OUTPUT	POLES	VOLTAGE
	3.7kW	6P	200V
ISO CLASS	M5		
WEIGHT	660 kg		

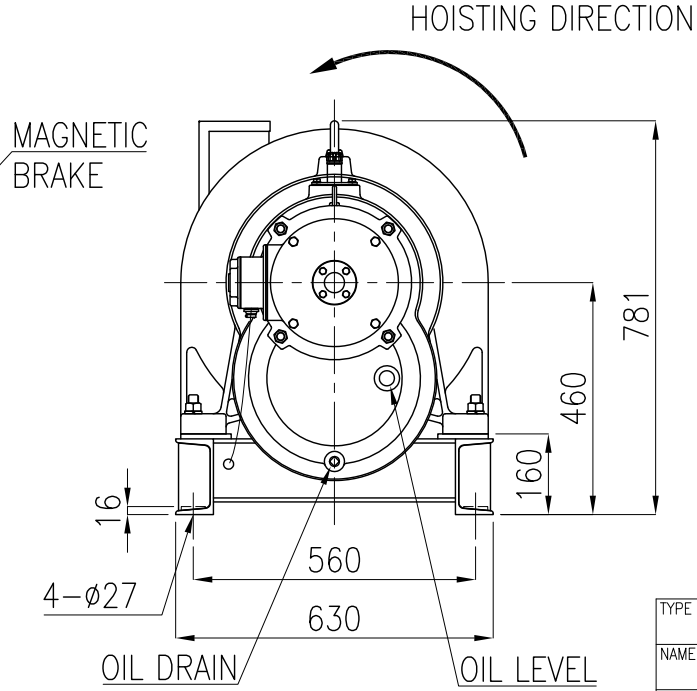
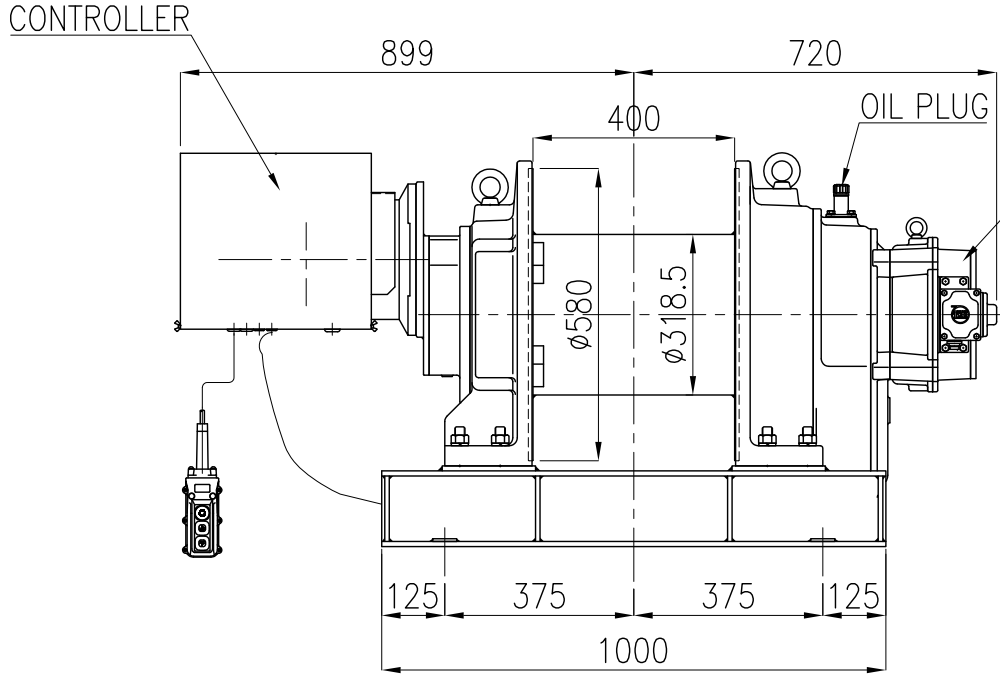

TYPE	MA-25G10(S)
NAME	OUTLINE
DRAWN No.	051468