

# SPECIFICATION

MODEL	MA-5G16(S)		
FREQUENCY	50 Hz	60 Hz	
RATED LOAD	650 kg	550 kg	
ROPE SPEED	16 m/min	20 m/min	
LENGTH OF WINDING	ø10×150m (7Ls)		
MOTOR	OUTPUT	POLES	VOLTAGE
	2.5kW	4P	200V 3相
ISO CLASS	M5		
WEIGHT	230 kg		

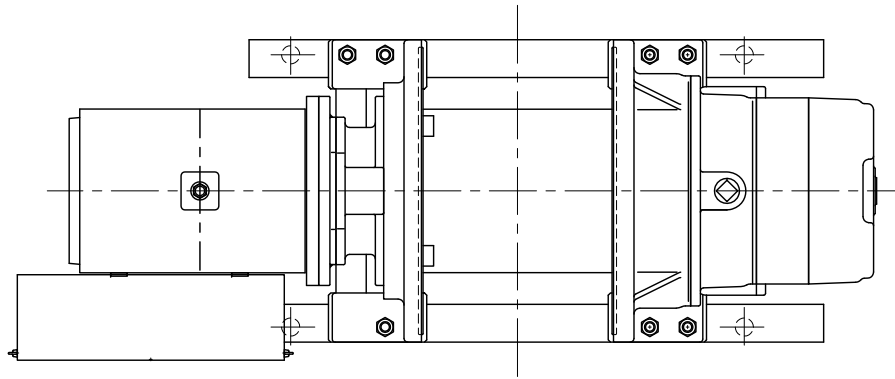

CONTROLLER

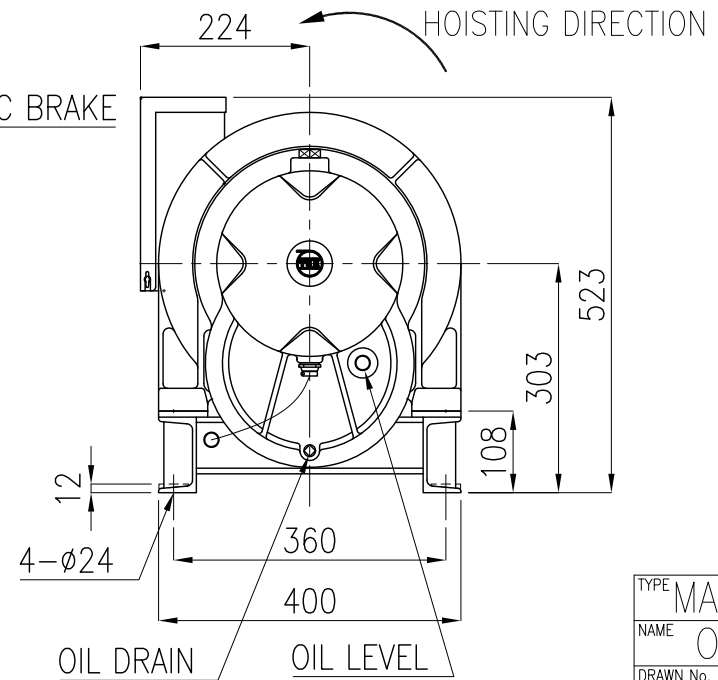
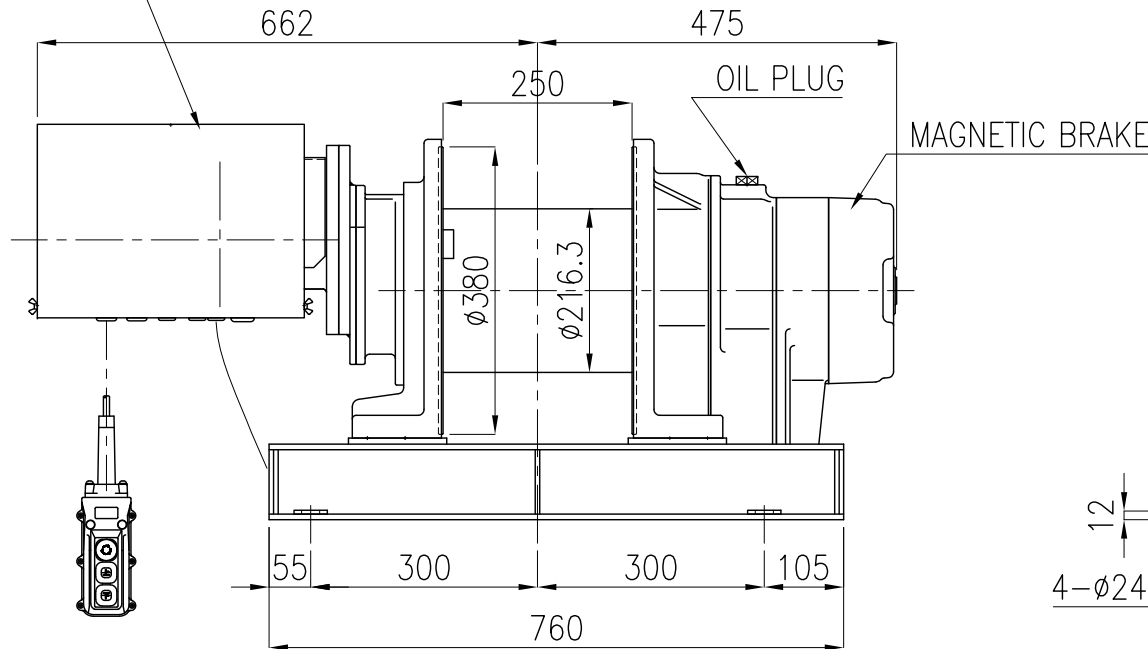

TYPE	MA-5G16(S)
NAME	OUTLINE
DRAWN No.	051461