

SPECIFICATION

MODEL	MA-50		
FREQUENCY	50 Hz	60 Hz	
RATED LOAD	4000 kg	3300 kg	
ROPE SPEED	53 m/min	63 m/min	
LENGTH OF WINDING	φ20×190m, φ20×80m×2		
MOTOR	OUTPUT	POLES	VOLTAGE
	37kW	8P	200V
ISO CLASS	M5		
WEIGHT	2150 kg		

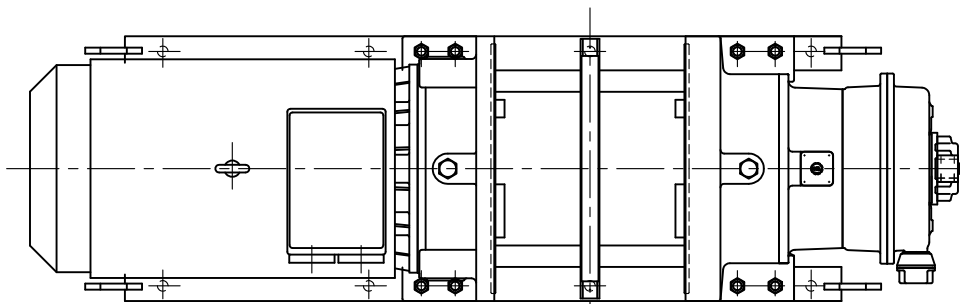

2474

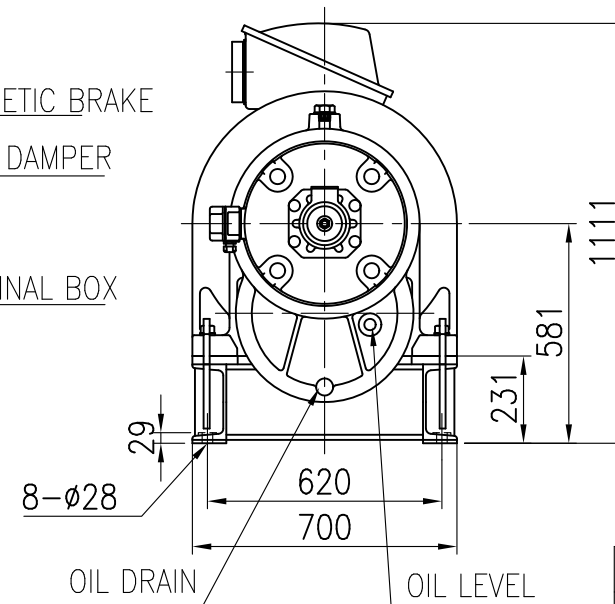
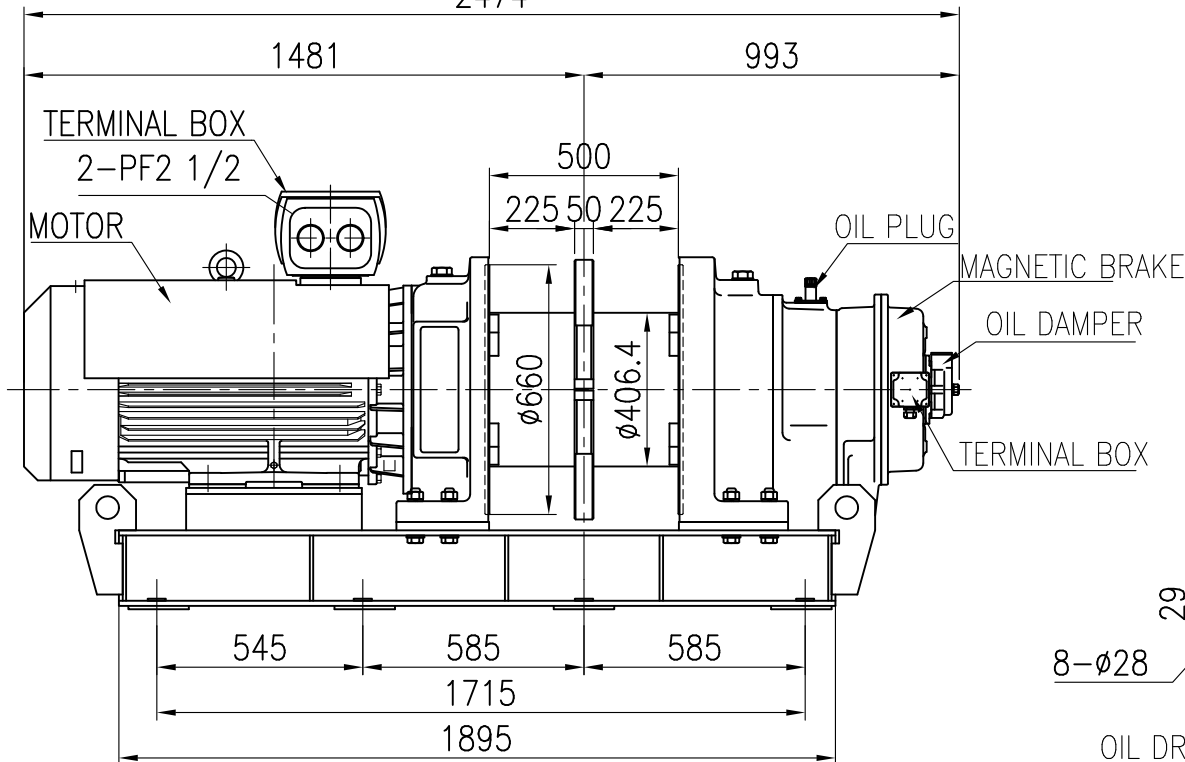

TYPE	MA-50
NAME	OUTLINE
DRAWN No.	026610